

## Installation Instructions

**Important note: Unlike traditional Celect accessories, Spec Series Trim must be installed prior to the installation of the Celect panels.**

### Outside Corner Post

- Place the corner post in position, allowing a 1/4" (6.4mm) gap between the top of the post and the eave or soffit. Position a nail at the top of the upper slot on both sides of the corner post, leaving a gap of approximately 1/32" (0.8mm) between the nail heads and the corner posts. The corner post hangs from these nails. The balance of the nailing should be in the center of the slot, 8" to 12" (203mm to 305mm) apart, again leaving 1/32" (0.8mm) between the nail head and the corner post. This allows for the expansion and contraction to occur at the bottom. The corner post should extend 1 1/2" (38.1mm) below the bottom of the starter strip. Cut away any exposed nail hems. NOTE: Posts must be straight, square and loosely fastened. Do not twist or flex posts over bowed or twisted wall surfaces.
- If more than one length of post is required, cut the bottom of the upper post and install as shown in figure 1.

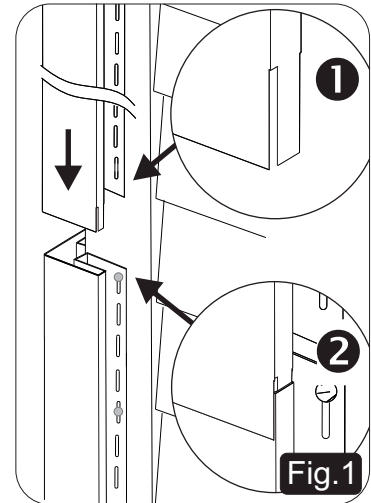

### Inside corners

- Inside corner posts are installed in the same manner as the outside posts.
- If more than one length of post is required, cut and install the second post as shown in figure 2.

### Wide Faced J Channel

- Wide faced J can be used as a siding receiver around areas such as windows, doors and anywhere the panels terminate and the panel expansion gap needs to be concealed.
- Fasten the channel every 8" to 12" (203mm to 305mm) placing the fastener in the center of the nailing slot(s) leaving approx. 1/32" (.8mm) space between the head of the fastener and the vinyl. Leave 1/4" where the channel terminates at corners, etc. to allow for expansion.
- If more than one length of channel is required or installing in a gable, cut and lap the two pieces as shown in figures 3 and 4.
- When installing wide faced J channel around windows and doors, begin with the sill or bottom piece, then the side jambs and finally the header piece.
- All notches and miter cuts are 2 1/2" (63.5mm).
- Overlap miters over adjoining pieces as shown.
- Make sure to retain tabs as shown.
- Secure the channel every 8" to 12" (203mm to 305mm) loosely, leaving approximately 1/32" (.8mm) gap between the head of the fastener and the vinyl.
- Secure in the center of the nailing slots except for *one* fastener at the top of the upper most slot on both side jamb pieces to hold in place. These fasteners must be loose also.

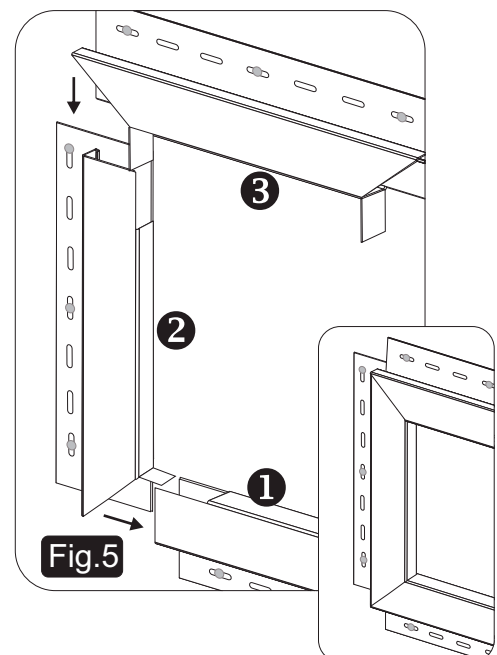
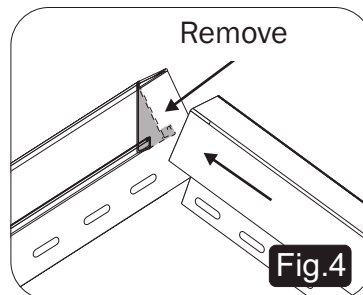
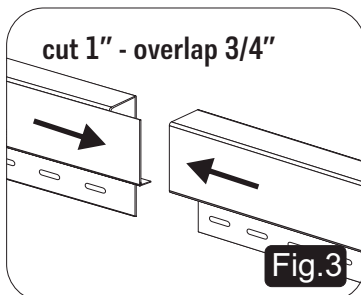
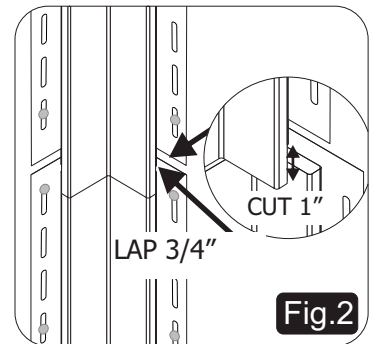

## Top Course Securing Options

### Option 1

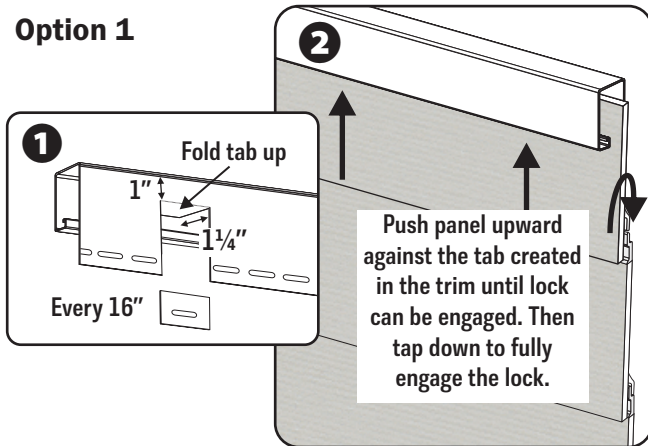

### Option 2

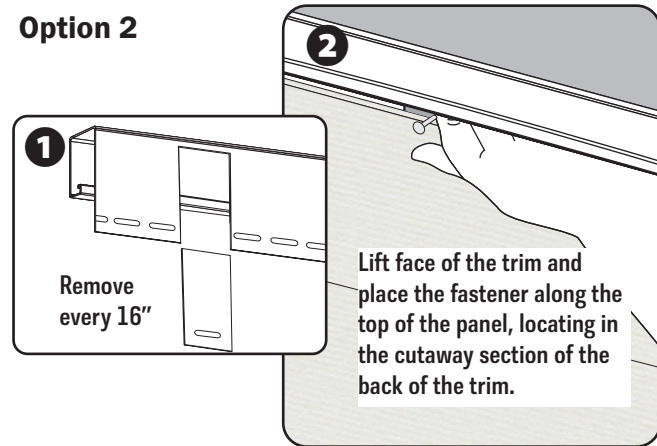

## Product Offering

### Outside Corner Post



- Product code: SPECOCPP
- 10' long with 8 pieces per box

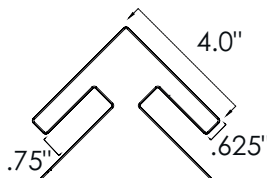

### Inside Corner Post



- Product Code: SPECICPP
- 10' long with 4 pieces per box

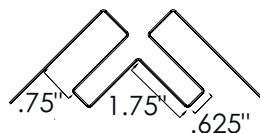

### Wide Faced J Channel



- Product code: SPECWFJ
- 12.5' long with 8 pieces per box

